

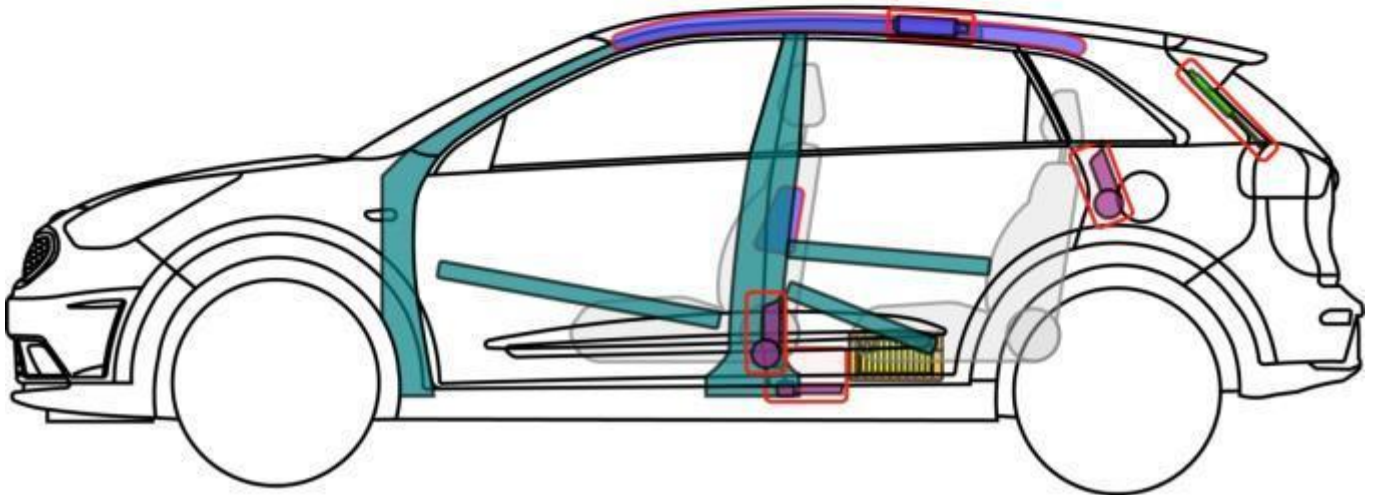

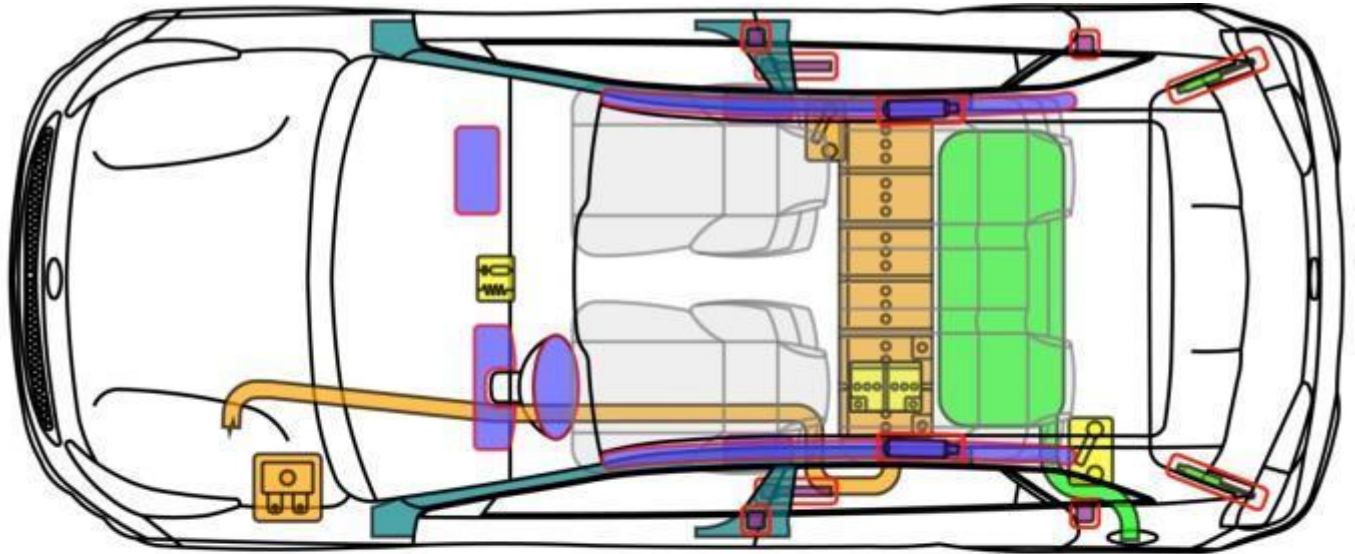





# Niro (DE HEV)

Guhera kuri modeli 2018-

12V muri bateri ya voltage iri hejuru (HV)



 <p>Umupira w'umutekano</p>	 <p>Agace k'imodoka gakomeye cyane</p>	 <p>Akuma gagenzura imikorere y'umutekano w'inyongera</p>	 <p>Bateri ya voltage iri hejuru</p>
 <p>Icuma kibika umwuka utera Umupira w'umutekano kuzura igihe habaye impanuka</p>	 <p>Ikoranabuhanga ririnda abagenzi iyo imodoka igiye kugwa cyangwa kwihirika ryikoresha</p>	 <p>Bateri ifite amashanyarazi make</p>	 <p>Insinga cyangwa igice cy'amashanyarazi menshi cyane</p>
 <p>Akuma gakaza umukandara igihe habaye impanuka</p>	 <p>Impombo y'umwuka ifasha gufungura no gufunga ibice by'imodoka</p>	 <p>Ikigega cya lisansi</p>	 <p>Icyuma gitandukanya amashanyarazi ya voltage nyinshi</p>